

1xN SM PLC Splitter Module

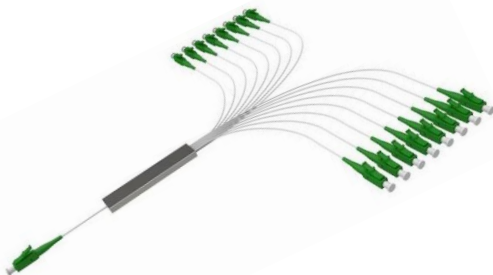

Planar lightwave circuit (PLC) splitter is a type of optical power management device that is fabricated using silica optical waveguide technology to distribute optical signals from Central Office (CO) to multiple premise locations. Bare fiber splitter is a kind of ODN product suitable for PON networks that can be installed in the pigtail cassette, test instrument and WDM system, which minimizes the space occupation.

Features

- Wide Wavelength
- Ultra Low Excess Loss
- Low PDL
- Highly Stable & Reliable
- High Uniformity
- Low Cost
- Telcordia Qualified

Applications

- Telecommunications
- FTTX
- CATV
- LAN
- Passive Optical Network (PON)

Specifications

Parameter	Min	Typical	Max	Unit
Wavelength	1260		1650	nm
Insertion Loss ^{[1], [2]}	1x2	4.0		dB
	1x4	7.3		
	1x8	10.8		
	1x16	13.8		
	1x32	17.2		
	1x64	20.5		
Uniformity	1x2	0.6		dB
	1x4	0.8		
	1x8	1.0		
	1x16	1.5		
	1x32	2.0		
	1x64	2.5		
PDL	1x2	0.2		dB
	1x4	0.2		
	1x8	0.2		
	1x16	0.3		
	1x32	0.3		
	1x64	0.3		
Return Loss		50		dB
Directivity		55		dB
Power Handling		300		mW
Working Temperature	-40		85	°C
Storage Temperature	-40		85	°C
Fiber type	Corning SMF28			
Connector Type	Custom specified			

Notes:

- [1]. Measured without connectors at room temperature
- [2]. For devices with connectors, add 0.3dB to the IL

Note: The specifications provided are for general applications with a cost-effective approach. If you need to narrow or expand the tolerance, coverage, limit, or qualifications, please [\[click this link\]](#):

Legal notices: All product information is believed to be accurate and is subject to change without notice. Information contained herein shall legally bind Agiltron only if it is specifically incorporated into the terms and conditions of a sales agreement. Some specific combinations of options may not be available. The user assumes all risks and liability whatsoever in connection with the use of a product or its application.

Rev 06/03/24

1xN SM PLC Splitter Module

DATASHEET

Mechanical Dimensions (mm)

■ Standard PLC

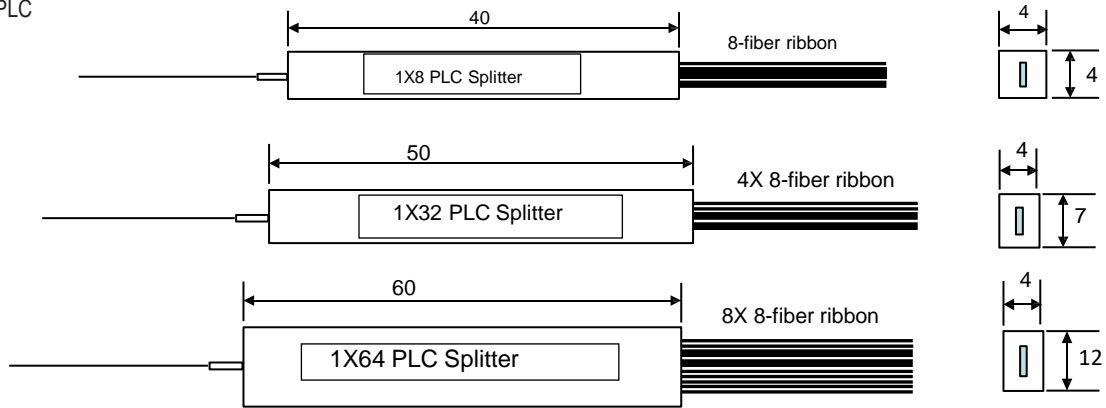

■ PLC Mini-Module

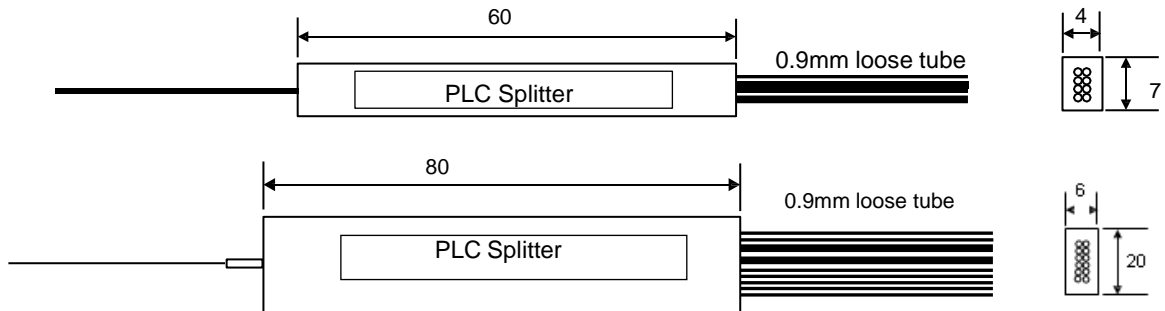

*Product dimensions may change without notice. This is sometimes required for non-standard specifications.

1xN SM PLC Splitter Module

DATASHEET

Mechanical Dimensions (mm)

■ PLC Module

100 x 8 x 10

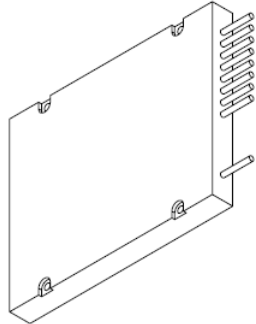
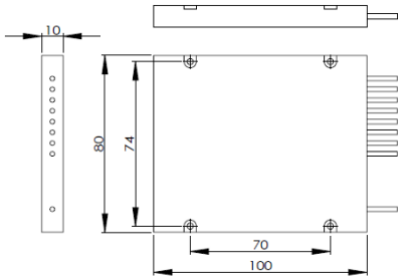

120 x 80 x 8

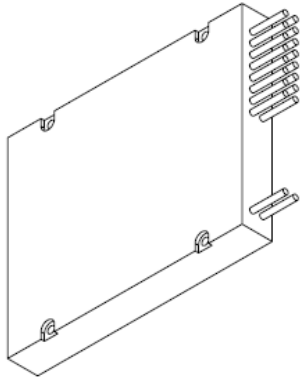
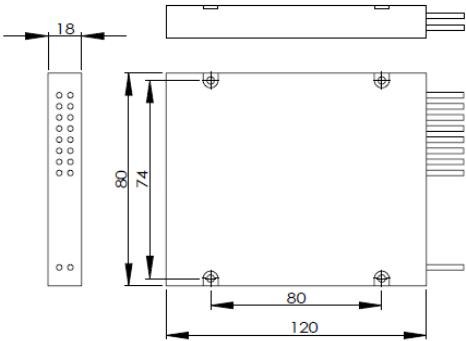

140 x 115 x 18

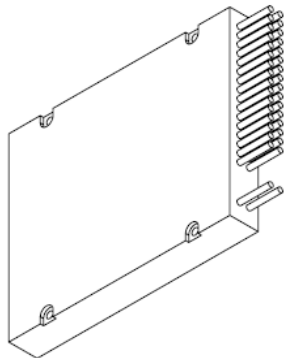
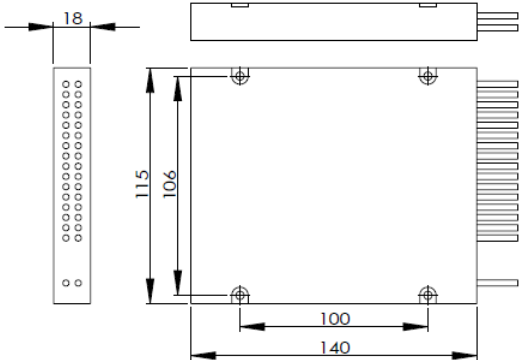

*Product dimensions may change without notice. This is sometimes required for non-standard specifications.

1xN SM PLC Splitter Module

DATASHEET

Ordering Information

Prefix	Wavelength	Port	Package	Fiber Type	Fiber Length	Input Connector	Output Connector
PSM1-	1310 = 1 1550 = 2 C+L = 6 Special = 0	1x2 = 02 1x4 = 04 1x8 = 08 1x16 = 16 1x32 = 32 1x64 = 64	Standard = 1 Mini module = 2 Module = 3	250um = 1 900um tube = 3 Special = 0	0.25m = 1 0.5 m = 2 1.0 m = 3 1.5 m = 4 2.0 m = 5 Special = 0	None = 1 FC/PC = 2 FC/APC = 3 SC/PC = 4 SC/APC = 5 ST/PC = 6 LC/PC = 7 LC/APC = A LC/UPC = U Special = 0	None = 1 FC/PC = 2 FC/APC = 3 SC/PC = 4 SC/APC = 5 ST/PC = 6 LC/PC = 7 LC/APC = A LC/UPC = U Special = 0

Fiber Core Alignment

Note that the minimum attenuation for these devices depends on excellent core-to-core alignment when the connectors are mated. This is crucial for shorter wavelengths with smaller fiber core diameters that can increase the loss of many decibels above the specification if they are not perfectly aligned. Different vendors' connectors may not mate well with each other, especially for angled APC.

Fiber Cleanliness

Fibers with smaller core diameters (<5 μm) must be kept extremely clean, contamination at fiber-fiber interfaces, combined with the high optical power density, can lead to significant optical damage. This type of damage usually requires re-polishing or replacement of the connector.

Maximum Optical Input Power

Due to their small fiber core diameters for short wavelength and high photon energies, the damage thresholds for device is substantially reduced than the common 1550nm fiber. To avoid damage to the exposed fiber end faces and internal components, the optical input power should never exceed 20 mW for wavelengths shorter 650nm. We produce a special version to increase the how handling by expanding the core side at the fiber ends.